



## LuK Service Info



# Part Nr. 130 0005 10 – 320mm DGVM

## JOHN DEERE – 2130 & 2135

Manufacturer: JOHN DEERE

Model: 2130 & 2135

Art.-Nr.: 130 0005 10

Info: 130 0005 10 replaces/ersetzt/  
remplace/sustituye a/sostituisce  
130 0005 20



Please ensure that flywheel is machined to  $\varnothing 326 \pm 0.3$  mm and to a pot depth of  $21.6 \pm 0.25$  mm. The clutch should be fitted with 6 x 3/8" UNC x 2 3/4" bolts.



Der Schwungrad Durchmesser muss auf  $\varnothing 326 \pm 0,3$  mm ausgedreht werden. Die Schwungradtiefe ist  $21.6 \pm 0.25$  mm. Die LuK-Kupplungsdruckplatte ist mit Befestigungsschrauben 6 x 3/8" UNC x 2 3/4" zu verbauen.



Assurez-vous que le diamètre du volant-moteur a été alésé à  $\varnothing 326 \pm 0,3$  mm et que la profondeur est de  $21.6 \pm 0.25$  mm. L'embrayage doit être monté avec des vis de fixation 6 x 3/8" UNC x 2 3/4".



Por favor, asegúrese de que el volante-motor está mecanizado a  $\varnothing 326 \pm 0,3$  mm y a una profundidad de  $21.6 \pm 0.25$  mm en la zona de fricción. El embrague LuK debe ir montado con tornillos de fijación 6 x 3/8" UNC x 2 3/4".



Controllare il volano sia stato rettificato a  $\varnothing 326 \pm 0,3$  mm e ad una profondità di  $21.6 \pm 0.25$  mm. La frizione deve essere installata con 6 bulloni da 3/8" UNC x 2 3/4".

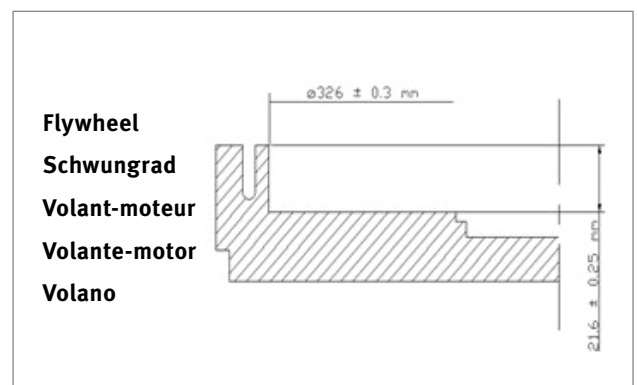

- For accurate model information please see LuK catalogue
- Die genaue Fahrzeugzuordnung entnehmen Sie bitte dem LuK-Katalog
- Pour plus d'information sur les applications veuillez vous référer au catalogue LuK
- Para obtener información sobre el modelo, rogamos consulte el catálogo de LuK
- Per informazioni sul modello consultare il catalogo LuK

### You want more? We can help!

Phone: +44 (0) 1432 264 264

Fax: +44 (0) 1432 375 760

aftermarket.uk@schaeffler.com

www.repxpert.co.uk

SCHAEFFLER  
REPXPERT