



LuK Service Info



Part Nr. 331 0235 10 — 305 mm TDCA – 10 spline

Manufacturer: CASE IH

McCORMICK

Info:

Flywheel Modification/
Schwungradänderung/
Modification du volant-moteur/
Modificar el Volante-motor/
Modifica volano

Model:

C80, C90, C100, CX80, CX90, CX100
CX80, CX85, CX90, CX95, CX100, CX105

Art.-Nr.:

331 0235 10



631 2459 09 = 131 0254 10 + 331 0235 10

631 2459 10 = 131 0254 10 + 331 0235 10 + 500 1046 50 + 410 0026 41



Re-machine the flywheel inner recess to a diameter of $186 \pm 0.5\text{mm}$ and a depth of 6mm to avoid rivets contacting flywheel.

profondeur de 6mm pour éviter que les rivets ne touchent le volant-moteur.



Die innere Eintiefung des Schwungrads muss auf einen Durchmesser von $186 \pm 0.5\text{mm}$ und eine Tiefe von 6mm bearbeitet werden, um zu verhindern, dass Nieten mit dem Schwungrad in Berührung kommen.



Rectifi que el hueco interior del volante motor con un diámetro de $186 \pm 0.5\text{mm}$ y una profundidad de 6mm, con el fin de evitar que entre en contacto con los remaches.



Ré-usinez la cavité intérieure du volant-moteur de sorte à obtenir un diamètre de $186 \pm 0.5\text{mm}$ et une



Rettifi care nuovamente la cavità interna del volano a un diametro di $186 \pm 0.5\text{mm}$ e una profondità di 6mm per evitare che i rivetti tocchino il volano.

4 Cylinder Flywheel
4 Zylinder Schwungrad
4 Cylindre Volant-moteur
4 Cilindro Volante-motor
4 Cilindro Volano

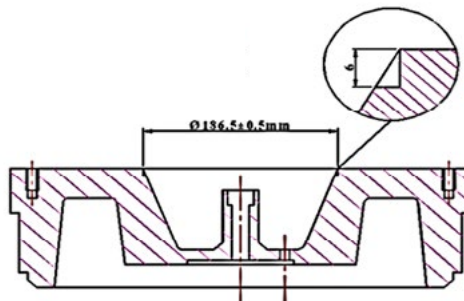

- For accurate model information please see LuK catalogue
- Die genaue Fahrzeugzuordnung entnehmen Sie bitte dem LuK-Katalog
- Pour plus d'information sur les applications veuillez vous référer au catalogue LuK
- Para obtener información sobre el modelo, rogamos consulte el catálogo de LuK
- Per informazioni sul modello consultare il catalogo LuK

You want more? We can help!

Phone: +44 (0) 1432 264 264

Fax: +44 (0) 1432 375 760

aftermarket.uk@schaeffler.com

www.repxpert.co.uk

SCHAEFFLER
REPXPERT