



PATENT-FREE WATER PUMP

FOR AUDI-VW

15001

FUNCTION

The main task of the water pump is to cool the heat which is produced from combustion in the engine block, and to transport it away to the surrounding air. The mechanical water pump thereby continuously supplies coolant which absorbs the heat and ensures the heat exchange in the engine block using circulation.

The pumping capacity for cooling the engine is directly proportional to the engine speed and is operated using a V-belt, V-ribbed belt or toothed belt over the belt pulley.

A valve controls the cooling, as required, in the electrically operated water pump and is independent of the engine speed.



SYMPTOMS

- Temperature of the engine increases
- Loss of large quantities of coolant
- Warning light for coolant and engine temperature lights red
- Increased fuel consumption



FAILURE CAUSES

- Corrosion in the cooling system
- Belt tension is not complied with
- Cooling system has not been cleaned
- An unsuitable coolant has been used



CONSEQUENTIAL DAMAGES

- Engine damage

VAICO-QUALITY

METAL IMPELLER



Audi	A3, A4 (1.6 TDI, 2.0 TDI)
VW	Golf VI, VII (1.6 TDI, 2.0 TDI), Touran (1.6 TDI, 2.0 TDI), Passat (1.6 TDI, 2.0 TDI)

X-Ref 04L 121 011 E

V10-50099

1. Independently of the controller, the VAICO water pump supplies 100% of the coolant through the coolant circuit at all times.
2. To avoid an error message from the electronics, the available valve must be mounted to the water pump despite it functioning incorrectly.
3. The faulty patented controller cannot tilt and this ensures a longer lifetime and better functioning of the VAICO water pump.
4. Please follow our assembly instructions.

Notes: Temporary offers are only valid while stocks last. All offers remain subject to prior sale. Our general terms and conditions of sale and delivery as well as our warranty conditions apply, which are available for download on our website. All prices are net prices. Errors excepted. Reference numbers of vehicle manufacturers are non-binding and no indication of origin. They may not be disclosed in invoices. © VIEROL AG

OE-QUALITY

PPS PLASTIC IMPELLER



1. Continuously opening and closing the patented controller leads to wear and there is a risk that this controller tilts to the lower position and no more coolant can flow through.
2. The result is that the temperature in the engine rises quickly. This can lead to total failure of the engine.



INSTALLATION INSTRUCCION, WATER PUMP

V10-50099

15001

OE-QUALITY



VAICO WATER PUMP NOT VARIABLE AND WITHOUT VALVE.

VAICO-QUALITY

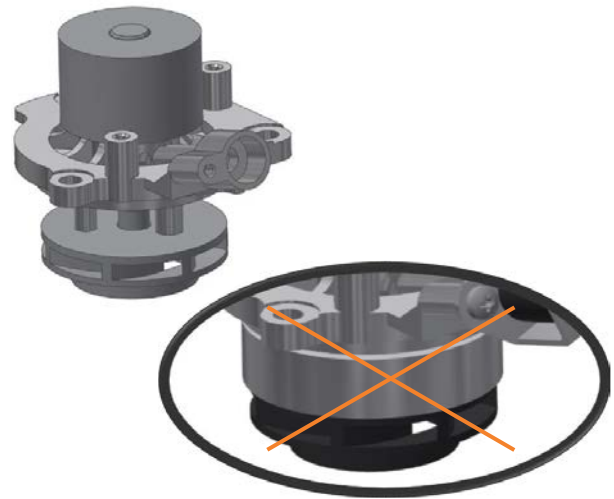

REUSE EXISTING OE VALVE FOR VAICO WATER PUMP!

VAICO-QUALITY



INSERT AND SCREW OE VALVE

VAICO-QUALITY

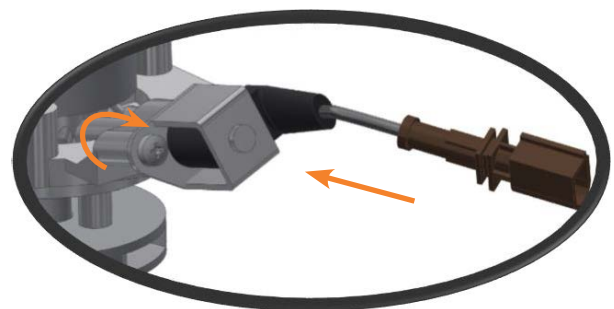

Notes: Temporary offers are only valid while stocks last. All offers remain subject to prior sale. Our general terms and conditions of sale and delivery as well as our warranty conditions apply, which are available for download on our website. All prices are net prices. Errors excepted. Reference numbers of vehicle manufacturers are non-binding and no indication of origin. They may not be disclosed in invoices. © VIEROL AG