

# SERVICE INFO

Page 1/2



## Hydraulic tensioning unit conversion kit 533 0097 10 and mechanical tensioning arm 533 0015 10 for BMW

### Vehicle

Manufacturer: BMW

### Models:

E34, E36, E38, E39,  
E46, E53, E60, E61,  
E65, E66, E83, Z3, Z4

### Engines:

**E34** 520, 525  
**E36** 320, 323, 325, 328  
**E38** 728  
**E39** 520, 523, 525, 528, 530  
**E46** 320, 323, 325, 328, 330  
**E53** 3.0  
**E60** 520, 525, 530  
**E61** 520, 525, 530  
**E65** 730  
**E66** 730  
**E83** 2.5, 3.0  
**Z3** 2.0, 2.2, 2.8, 3.0  
**Z4** 2.2, 2.5, 3.0

### OE Nos.:

11 28 1 427 252 (mech.)  
11 28 1 735 899 (mech.)  
11 28 1 748 832 (mech.)

### Part Nos.:

533 0015 10 (mech.)  
533 0097 10 (hydr.)

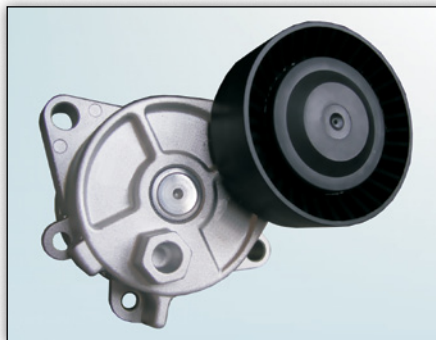

Image 1: 533 0015 10 (mechanical design)



Image 2: 533 0097 10 (hydraulic design)

The mechanical tensioning arm 533 0015 10 (Image 1) in the original equipment has been replaced by a tensioner with hydraulic damping (Image 2).

As an alternative, Schaeffler Automotive Aftermarket offers a conversion kit 533 0097 10 that, in addition to the hydraulic damper, contains all the necessary components required to convert from the mechanical to the hydraulic tensioner (Image 3).

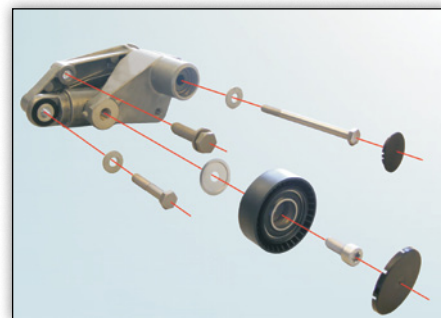

Image 3: 533 0097 10 – Scope of delivery

The package includes the relevant assembly instructions that illustrate how the components must be assembled.

### Note:

Page 2 of this Service Information sheet shows the correct installation positions of the two tensioner designs.

# SERVICE INFO

Page 2/2



## Hydraulic tensioning unit conversion kit 533 0097 10 and mechanical tensioning arm 533 0015 10 for BMW

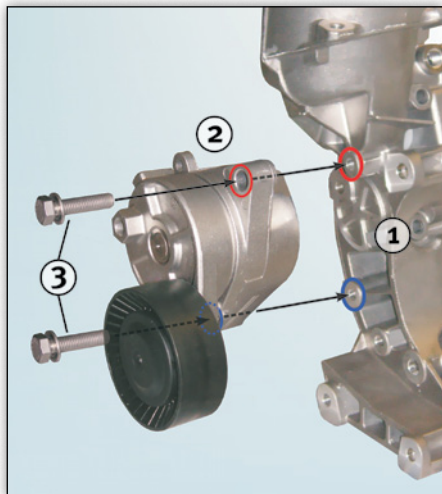

**Image 4:** Installation position of the mechanical tensioning arm

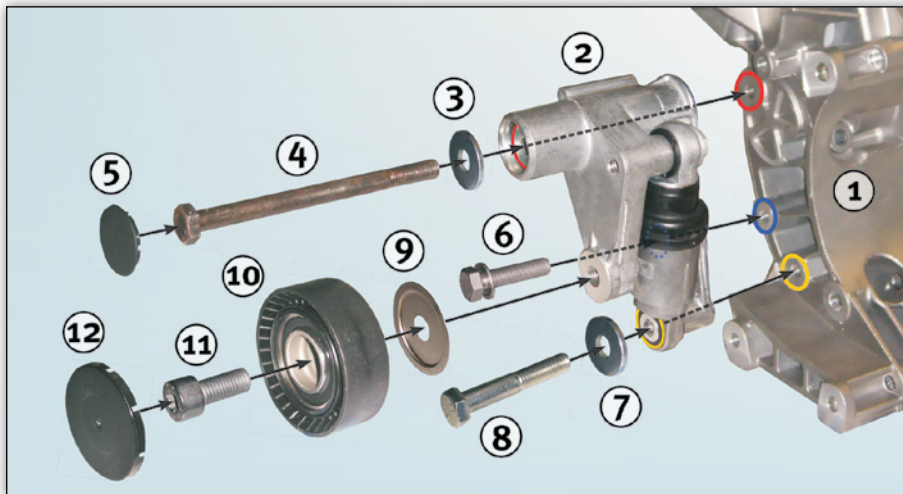

**Image 5:** Installation position of the hydraulic conversion kit 533 0097 10 with all the relevant components

### Key to image 4:

- (1) Holder on engine block\*
- (2) Tensioning arm 533 0015 10
- (3) Fixing bolts M8x35\*

### Key to image 5:

- (1) Holder on engine block\*
- (2) Tensioning arm 534 0009 10
- (3) Washer M8x21x2 mm
- (4) Bolt M8x105 mm
- (5) Cover 30x4.2 mm
- (6) Bolt M8x35 mm
- (7) Washer M8x21x2 mm
- (8) Bolt M8x50 mm
- (9) Plate M10x40x1.5 mm
- (10) Deflection pulley 532 0001 10
- (11) Bolt M10x25 mm
- (12) Cover 55x5 mm

### Note:

Note that different mounting holes must be used for the mechanical and hydraulic tensioner designs in order to ensure correct operation.

\*) Not included with part or kit+

Appropriate spare parts can be found in our on-line catalogue at [www.Schaeffler-Aftermarket.com](http://www.Schaeffler-Aftermarket.com) or in RepXpert at [www.RepXpert.com](http://www.RepXpert.com).

Issued 04.2010 (replaces 08.2009)  
**INA 0022**

Subject to technical changes  
© 2010 Schaeffler Automotive Aftermarket

### For further information:

Phone: +44 (0) 14 32 264 264\*

Fax: +44 (0) 14 32 375 760

Info@LuK-AS.co.uk

[www.Schaeffler-Aftermarket.com](http://www.Schaeffler-Aftermarket.com)

\* Calls from within the UK 08457 001100

